

## Comprehensive Steam Turbine Control for Various Applications

The 505 and 505E are microprocessor-based controls designed to operate steam turbines of all sizes including industrial sized steam turbines, small utility turbogenerators, or turboexpanders. The 505 controls steam turbines using one or two (split-stage) actuators to drive inlet steam valves, while the 505E controls single extraction and/or admission steam turbines. These field programmable digital controls use menu-driven software to guide site engineers on programming the control to a specific generator or mechanical drive application. The 505 or 505E can be configured to operate as a stand-alone unit or in conjunction with a plant's Distributed Control System.

### Benefits

- An industry standard reliable control with proven success
- Able to handle simple to complex single or dual valve system control in one low cost package
- Easy to configure and operate, with built-in security
- Built-in system protection
- Digital communication capabilities with Modbus<sup>®</sup> over RS-232/422/485
- Integral process control

### A Simple System

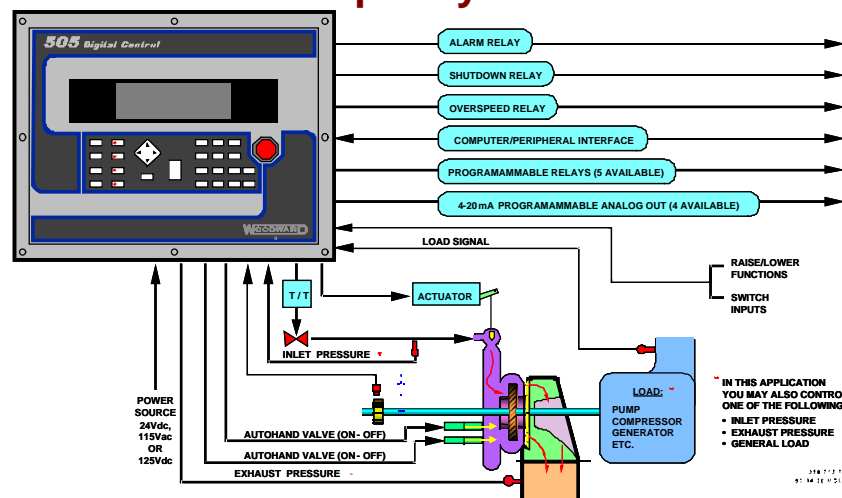

### to a Complex System

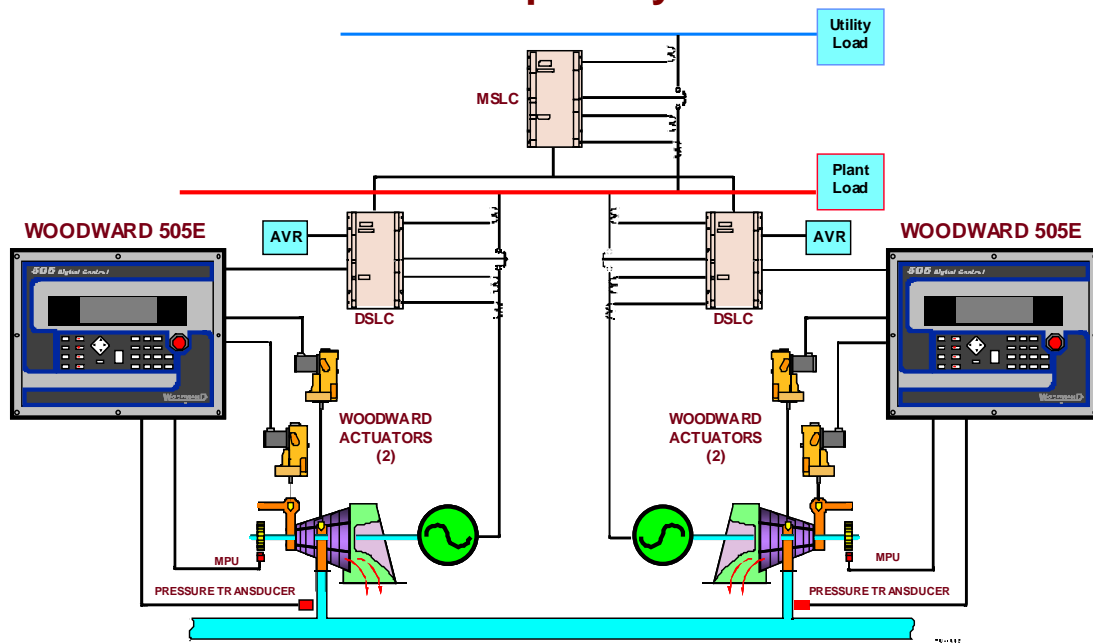



The **505 and 505E** are microprocessor-based controls designed to operate steam turbines of all sizes. The 505 is designed to operate steam turbines using one or two (split-stage) actuators to drive inlet steam valves. The 505E is designed to operate single extraction and/or admission steam turbines. These digital controls are field programmable. They use menu-driven software to instruct site engineers on programming the control to a specific generator or mechanical drive application. The 505 or 505E can be configured to operate as a standalone unit or in conjunction with a plant's Distributed Control System.

(product spec 85005)



The **TG-13E and TG-17E actuators** are drop-in replacements for TG mechanical governors, and are self-contained electro-hydraulic actuators for use on steam turbines where isochronous control, load sharing, or other functions are required. They can be used with all available Woodward electronic governor controls and accessories.

(product spec 04044)

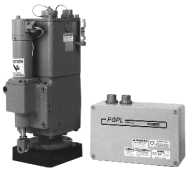

The **PGPL Actuator/Driver** is a drop-in replacement for PG-PL mechanical governors, and is an electro-hydraulic actuator with a proportional driver interface which can be used with electronic controls providing a 0 to 200 mA position signal. The actuator is designed for use with Woodward controls.

(product spec 37520)



The **TM-25LP and TM-200LP** actuators are electro-hydraulic, proportional actuators for positioning steam and fuel-control valves requiring either 25 or 200 lb (111 or 890 N) of linear force.

(product spec 82451)



The electrically controlled **Hydraulic Amplifier** is a pilot operated, linear servo actuator with up to 3 inches (76 mm) of stroke and up to 4500 lb (20 kN) of force. The amplifier is capable of operating the control mechanisms for steam turbines or large engines which require relatively large forces and work capacity.

(product spec 89007)



The **DSLCTM** control is a microprocessor-based synchronizer and load control designed for use on three-phase ac generators equipped with Woodward or other compatible speed controls and compatible automatic voltage regulators. The DSLC control is a synchronizer, a load sensor, a load control, a dead bus closing system, and optionally a VAR/PF and process control, all integrated into one powerful, yet convenient package.

(product spec 02006)



The **MSLC** control is a microprocessor-based load control designed for three-phase electric power generation sites equipped with Woodward DSLC Digital Synchronizer and Load Control units which operate in parallel with the utility. The MSLC is a synchronizer, a utility load sensor, an import/export load level control, a power factor control, and a master process control.

(product spec 02021)



Designed for medium- and large-sized generators, the **EGCP-3** is a complete turbine/generator power management package designed to work with automatic voltage regulators and speed controls, and contains advanced IEEE protection algorithms, revenue-grade metering, individual control of utility and inter-tie breakers, added input/output capabilities and backward compatibility with Woodward DSLC/MSLC synchronizers. A network of up to 16 EGCP-3 controls can handle your most sophisticated base-load, peak shaving or backup power generation applications. Based on Woodward's powerful GAP<sup>TM</sup> application programming tools, the EGCP-3 can be easily customized.

(EGCP-3 LS Multi-unit Load Share product spec 03300)

(EGCP-3 MC Multi-unit Mains Controller product spec 03301)



PO Box 1519, Fort Collins CO, USA 80522-1519  
Ph: +1 (970) 482-5811

1000 East Drake Road, Fort Collins CO 80525  
Fax: +1 (970) 498-3058

[www.woodward.com](http://www.woodward.com)

This document is distributed for informational purposes only. It is not to be construed as creating or becoming part of any Woodward Governor Company contractual or warranty obligation unless expressly stated in a written sales contract.

© Woodward 2004, All Rights Reserved

06/3/F